

NOTES:

1. INTERPRET DRAWING PER:
ASME Y14.5-2009 DIMENSION AND TOLERANCING.
2. REMOVE ALL BURRS AND SHARP EDGES.
3. ALL SURFACES ARE TO BE FREE OF CONTAMINATES PRIOR TO FINISH OR SHIPPING.
4. BAG OR TAG PART(S) WITH
PART NUMBER, APPLICABLE DASH NUMBER, AND REVISION LEVEL.
5. MATERIAL:
6. FINISH:

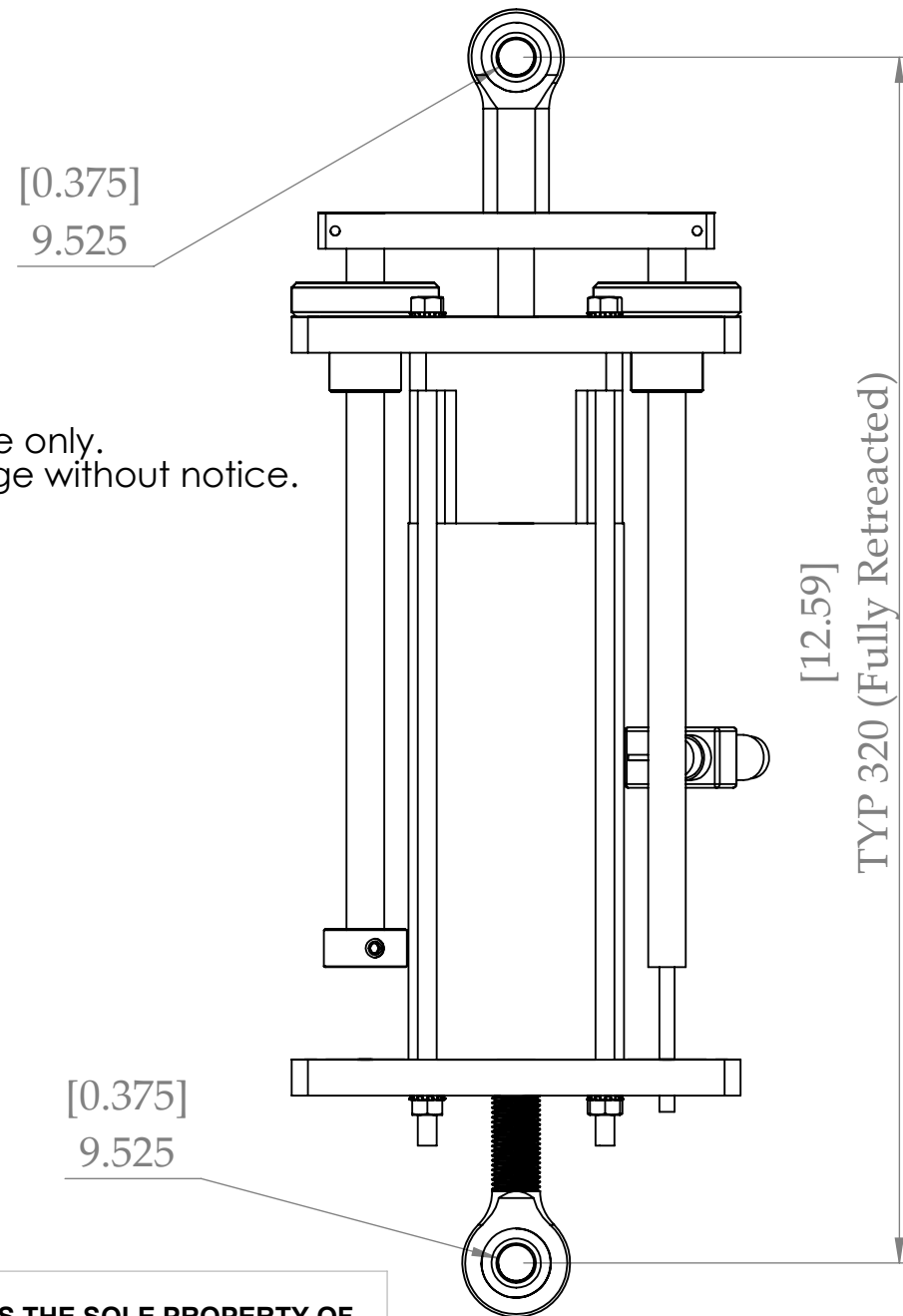

Document is for reference only.
Content subject to change without notice.

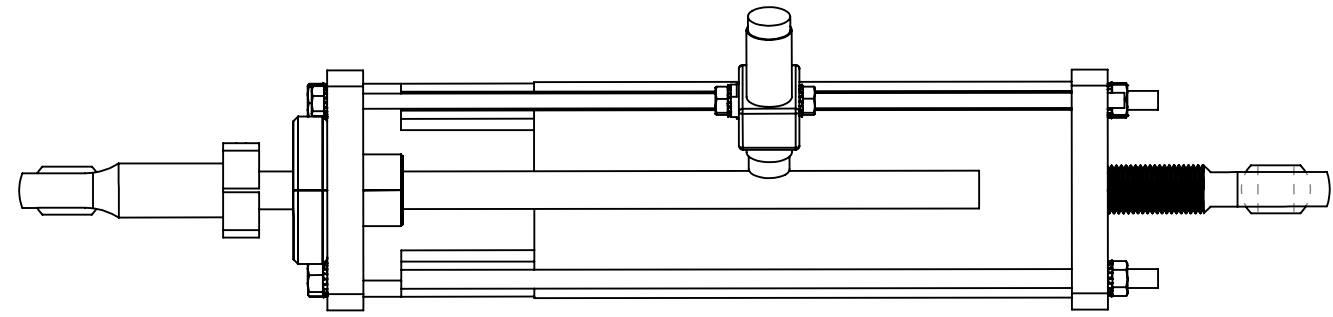
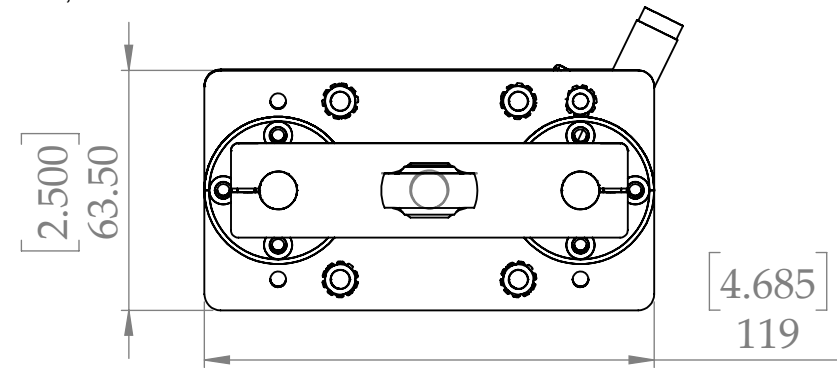
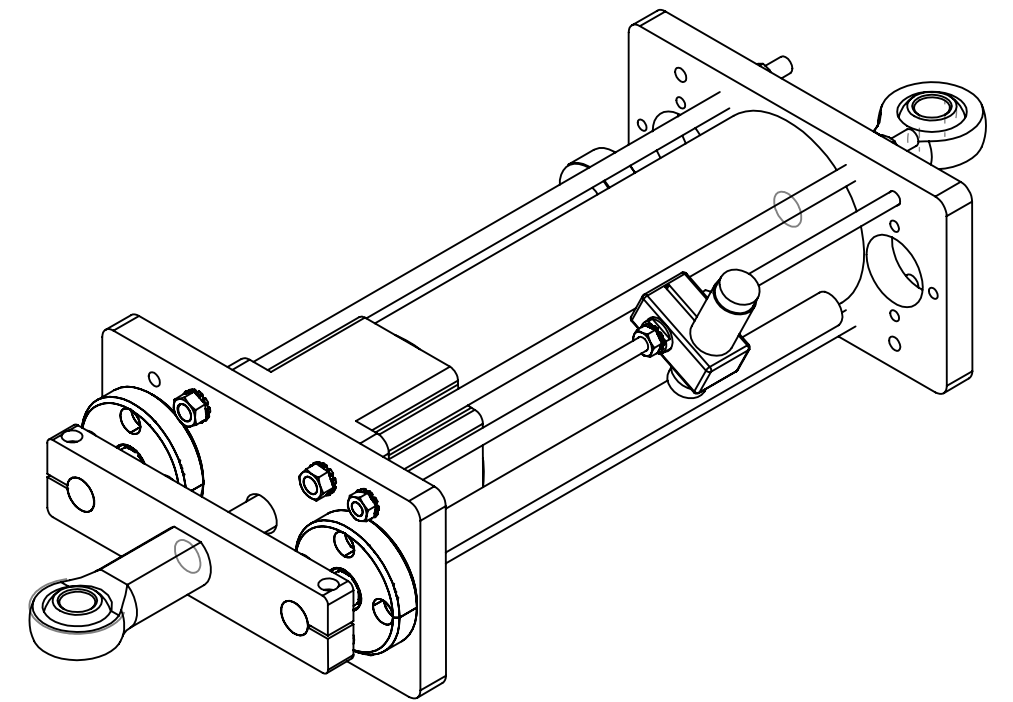

ALL DIMENSIONS ARE IN MM [IN]
 TOLERANCES UNLESS NOTED:
 INCH MILLIMETER
 X.XX +/- 0.01 X.X +/- 0.3
 X.XXX +/- 0.005 X.XX +/- 0.1
 THIRD ANGLE PROJECTION

REVISIONS			
APPD	DESCRIPTION	DATE	REV