

Every web guide control system would have a motor driver that takes the signal from the SCU5 controller and drives the stepper or servo actuator. A pre-wired motor communication cable from the SCU5 controller to motor driver would be supplied by Roll-2-Roll Technologies. The motor communication cable has two M8 4-pin female connectors.

MC QD 1140/1141/1240/1241

For intermediate web guides and upgrade kits MC QD 1140 or MC QD 1141 or MC QD 1240 or MC QD 1241 drivers can be used. The dimensions of the driver enclosure are shown below. All units in mm [in].

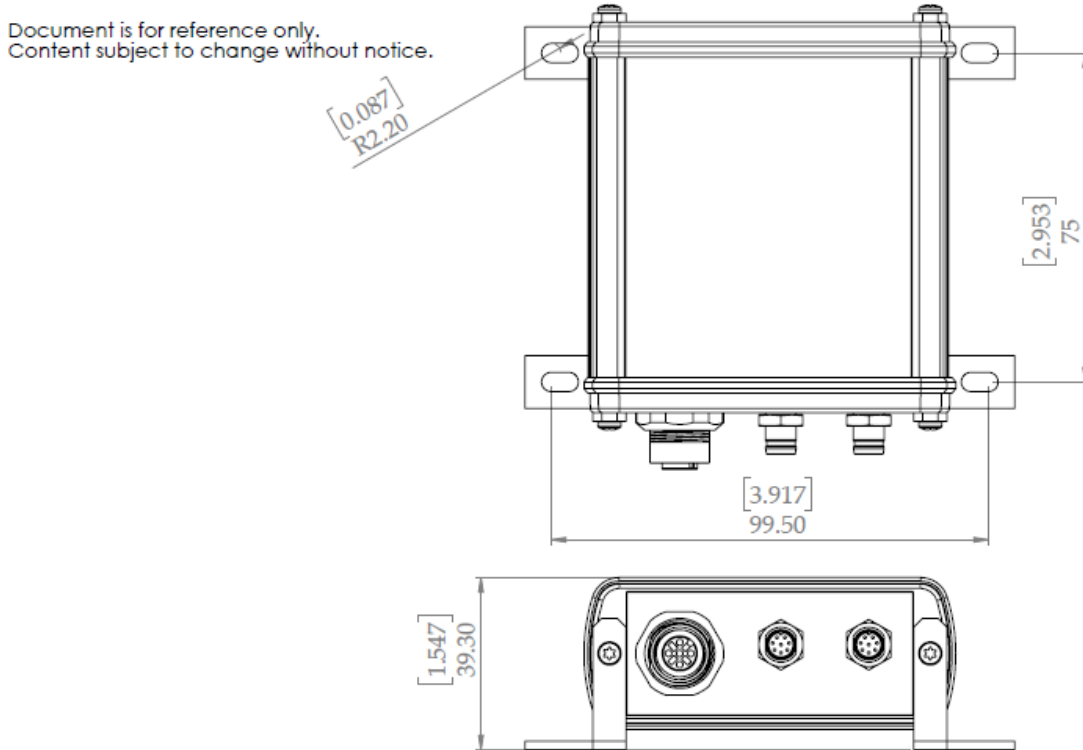

The driver can be mounted in a machine cabinet or on the machine frame close to the web guide, as long as the enclosure is properly grounded. The mounting screws or the wall mounting brackets can be used for grounding purposes.

Actuator Output

M12 4-pin female connector provides the actuator output signal from the driver. Pre-wired actuator power cable that connects the motor, that is part of the actuator, to the driver. The actuator power cable has one M12 4-pin male connector and one M12 4-pin female connector. Bi-polar 4-wire stepper motors with maximum current of 2.8 amps per coil can be connected to the motor driver using this port. The corresponding pin assignment is shown below.

Pin	1 - Brown	2 - White	3 - Blue	4 - Black
Function	OB2	OB1	OA2	OA1

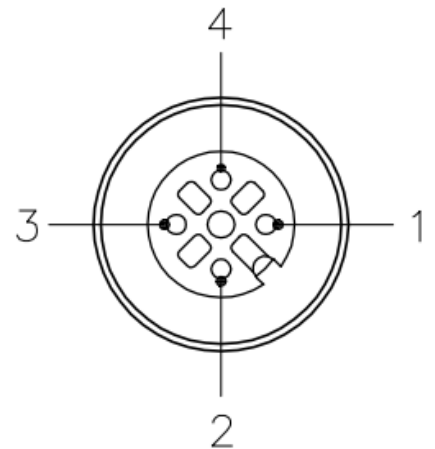

WARNING: Never connect or disconnect the actuator cable when the SCU5 controller is powered ON. All connections should be made prior to powering the SCU5 controller ON.

WARNING: Never interrupt this cable using a relay or switch. The motor coils may be energized during the interruption and this can cause severe damage to the driver and the motor.

Servo Center and Limit Switches

M8 6-pin male connector (shown on the right) is used for servo center and limit switch sensors. Pre-wired cable with an inductive proximity sensor is available for the servo center functionality.

The servo center used is a 24V compatible normally open NPN inductive proximity sensor. The inductive proximity sensor can be installed in such a way to find the center or home position of the web guide. A normally closed inductive proximity sensor can also be used if the servo center polarity is changed appropriately on the SCU5 controller.

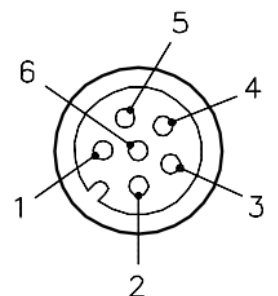

Apart from the servo center sensor, two limit switches can be used to limit the motion of the actuator in either direction. When the normally closed switch is open the driver prevents the actuator motion in that direction. The circuit is normally closed by connecting the corresponding cable to the ground pin. This functionality needs to be enabled in the SCU5 controller. The corresponding pin assignments are shown below.

Pin	1 - Brown	2 - White	3 - Blue	4 - Black	5 - Gray	6 - Pink
Function	VDD (24 V)	Left Limit Switch	Ground	Servo Center	Right Limit Switch	No Connection

The two limit signals can also be used to limit the actuator motion for other reasons. They can both be tied together to a switch that can be opened whenever the actuator motion needs to be stopped. When that switch is closed (by connecting both the left and right limit switch cables to ground) the actuator motion will not be inhibited by the driver. For example, the switch can be triggered when the machine is stopped or when the web is not in tension.

NOTE: Both the limit switch wires should be tied to the switch to ensure that the actuator does not move in either direction.

WARNING: The actuator may not move if this cable is disconnected in certain cases.

Power and Communication

A pre-wired motor communication cable is connected to this port. For this particular driver, the cable provides both power (24 VDC) and the communication signal to the driver from the SCU5 controller. The pin assignments are shown below.

Pin	1 - Brown	2 - White	3 - Blue	4 - Black
Function	VDD (24V)	RS485 B-	RS485 A+	GND

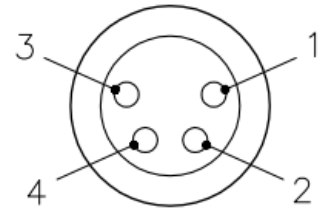

WARNING: Never connect or disconnect the motor communication cable when the SCU5 controller is powered ON. All connections should be made prior to powering the SCU5 controller ON.

WARNING: Do not interrupt this cable or the power to this driver to prevent the actuator from moving. Alternatively use the limit switch functionality above or provide an I/O signal to the SCU5 controller.

NOTE: When the SCU5 is powered on the SCU5 controller sends driver parameters to the driver. These driver parameters are stored in the memory of the SCU5 controller and not on the driver. Hence removing this cable and reconnecting the cable will not update the proper driver parameters from the SCU5 controller.

WARNING: The motor driver does not have reverse polarity protection. A reverse polarity will permanently damage the driver. Hence if the SCU5 controller is powered in reverse polarity this will damage the driver. First check and ensure that the SCU5 powers and it is wired with correct power polarity.

MC QD 1180/1181/1211/1230/1231/1260

For large actuators 1180 or 1181 or 1211 or 1230 or 1231 or 1260 are used. All these drivers have a separate power supply with higher wattage in order to actuate higher loads. Depending on the driver model 24 V (MC QD 1181/1211/1230) or 48 V (MC QD 1180/1231/1260) power may be supplied to the driver using a power supply that can supply up to 6 Amps of rms current.

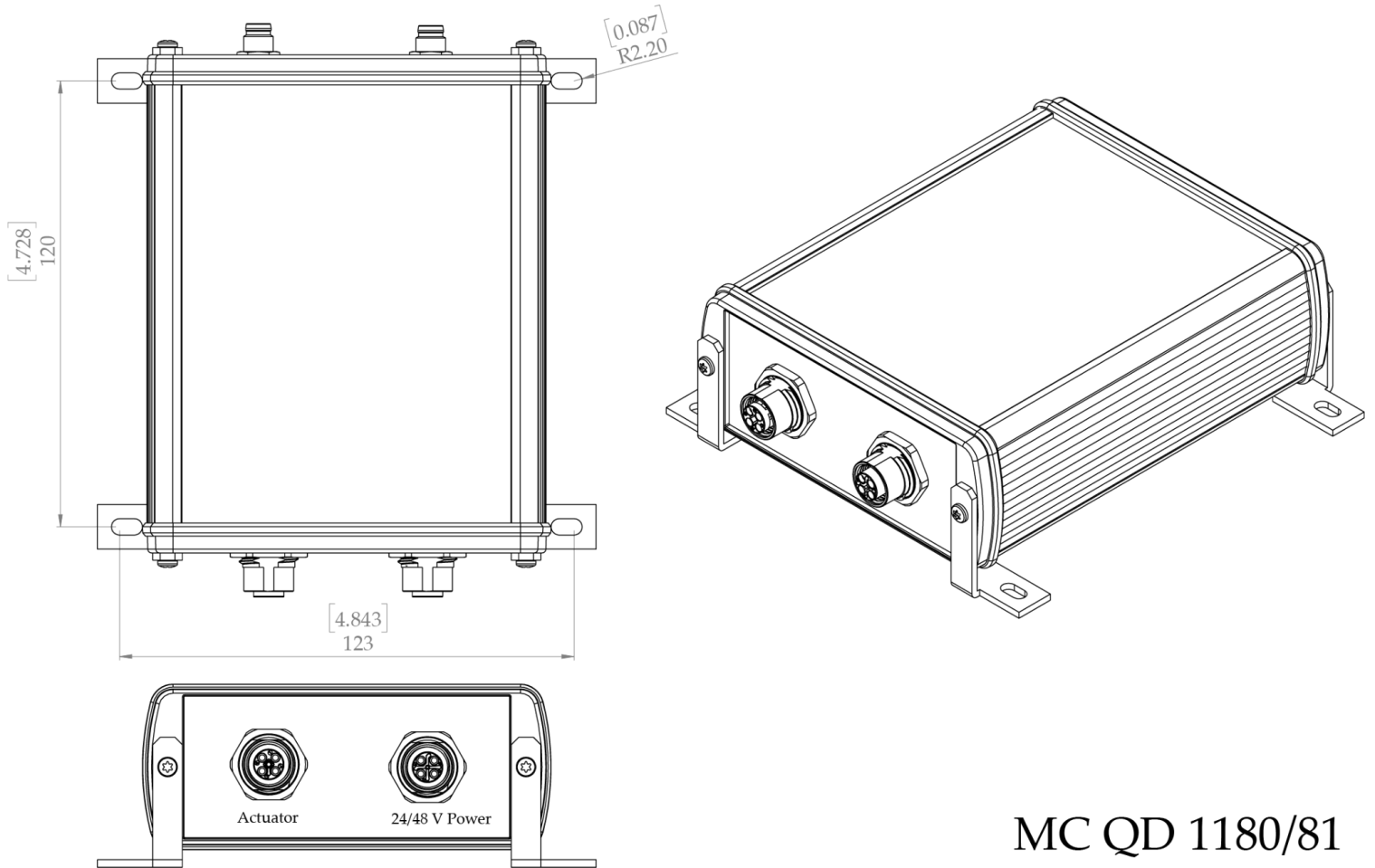

MC QD 1180/81

Communication

A pre-wired motor communication cable is connected to this port. This connector is the same as the one in MC QD 1140/41. Please see the information in preceding pages for more information. For this particular driver, the cable provides both power (24 VDC) and the communication signal to the driver from the SCU5 controller. However, since the current requirements are higher for high thrust actuators, the 24 V DC from the SCU5 is not used to power the driver.

WARNING: Never connect or disconnect the motor communication cable when the SCU5 controller is powered ON. All connections should be made prior to powering the SCU5 controller ON.

Actuator Output

M12 4-pin T-coded female connector provides the actuator output signal from the driver. Pre-wired actuator power cable that connects the motor, that is part of the actuator, to the driver. The actuator power cable has one M12 4-pin T-coded male connector and one M12 4-pin T-coded female connector. The pin assignments are shown below.

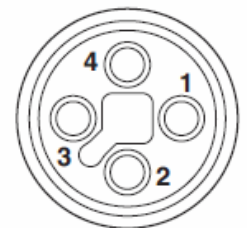

Pin	1 - Brown	2 - White	3 - Blue	4 - Black
Function	OB2	OB1	OA2	OA1

WARNING: Never connect or disconnect the actuator cable when the SCU5 controller is powered ON. All connections should be made prior to powering the SCU5 controller ON.

Servo Center and Limit Switches

M8 6-pin male connector is used for servo center and limit switch sensors. Pre-wired cable with an inductive proximity sensor is available for the servo center functionality. This connector is the same as the one in MC QD 1140/41. Please see the information in preceding pages for more information.

WARNING: The actuator may not move if this cable is disconnected.

Driver Power

M12 4-pin S-coded female connector is used to provide power to the motor driver. 24/48 V DC Driver Power Cable is supplied by Roll-2-Roll Technologies to connect a power supply to the driver. If the driver power cable is made by the customer the pin out for the cable are as follows.



Pin	Color	Signal
1	Red	+24 or +48 VDC
2		No connection
3	Black	Ground/Common

WARNING: MC QD 1181 operates with a maximum voltage of 26 V. Never supply more than 26 V for this driver.

WARNING: MC QD 1211 operates with a maximum voltage of 26 V. Never supply more than 26 V for this driver.

WARNING: MC QD 1230 operates with a maximum voltage of 26 V. Never supply more than 26 V for this driver.

WARNING: MC QD 1180 operates with a maximum voltage of 50 V. Never supply more than 50 V for this driver.

WARNING: MC QD 1260 operates with a maximum voltage of 50 V. Never supply more than 50 V for this driver.

WARNING: MC QD 1231 operates with a maximum voltage of 50 V. Never supply more than 50 V for this driver.

WARNING: The motor drivers do not have reverse polarity protection. So never power the motor driver in reverse polarity. This will permanently damage the driver.

NOTE: Always power the MC QD 1180/1181/1211/1230/1231/1260 and SCU5 MD at the same time. If a time delay is needed then always power the motor driver first before powering the SCU5 MD. This is because the motor parameters are loaded from the SCU5 MD to the motor driver on start-up.

MC QD 1161

For medium sized actuators 1161 can be used. Similar to the MC QD 1140/1141 the power to the driver is provided from the SCU5 MD controller via the motor communication cable.

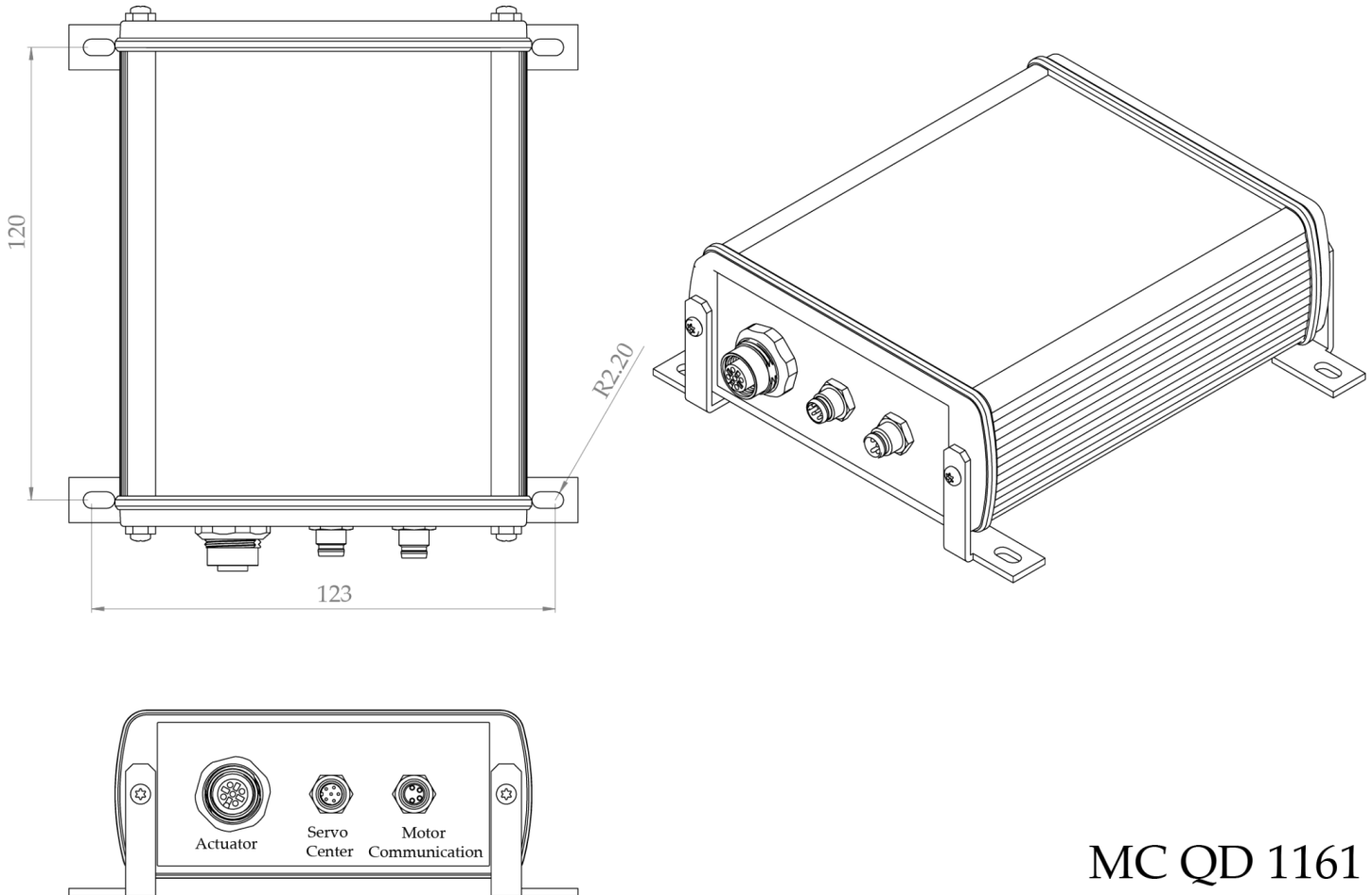

MC QD 1161

The driver can be mounted in a machine cabinet or on the machine frame close to the web guide, as long as the enclosure is properly grounded. The mounting screws or the wall mounting brackets can be used for grounding purposes.

Actuator Output

M12 4-pin female connector provides the actuator output signal from the driver. Pre-wired actuator power cable that connects the motor, that is part of the actuator, to the driver. The actuator power cable has one M12 4-pin male connector and one M12 4-pin female connector. This connector is the same as the one in MC QD 1140/41. Please see the information in preceding pages for more information.

WARNING: Never connect or disconnect the actuator cable when the SCU5 controller is powered ON. All connections should be made prior to powering the SCU5 controller ON.

Servo Center and Limit Switches

M8 6-pin male connector is used for servo center and limit switch sensors. Pre-wired cable with an inductive proximity sensor is available for the servo center functionality. This connector is the same as the one in MC QD 1140/41. Please see the information in preceding pages for more information.

WARNING: The actuator may not move if this cable is disconnected.

Power and Communication

A pre-wired motor communication cable is connected to this port. For this particular driver, the cable provides both power (24 VDC) and the communication signal to the driver from the SCU5 controller. This connector is the same as the one in MC QD 1140/41. Please see the information in preceding pages for more information.

WARNING: Never connect or disconnect the motor communication cable when the SCU5 controller is powered ON. All connections should be made prior to powering the SCU5 controller ON.